

Chapter 6 ✎

StudioCard Theory of Operation

✎ Overview.....	6-3
✎ Block Diagram.....	6-4
✎ Analog Audio.....	6-5
✎ Digital Audio.....	6-6
✎ Sample Clock Generator.....	6-7
✎ MIDI.....	6-8
✎ SMPTE (LTC).....	6-9
✎ Video.....	6-10
✎ DSP	6-11

This page intentionally left blank.

Overview The *StudioCard* is a high performance digital audio adapter for use in personal computers using the PCI expansion bus. This chapter explains in detail the hardware features and functions of the *StudioCard*.

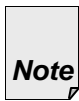

Knowledge of how the StudioCard works is not necessary for operation.

Block Diagram The *StudioCard* consists of various functional blocks that handle analog audio, digital audio, sample clock generation, MIDI, and SMPTE time code that are driven by a floating point DSP. The DSP handles data transfers and communication with the host PC through shared memory and a PCI interface. A block diagram of the *StudioCard* is depicted in the figure below and is described in the sections that follow.

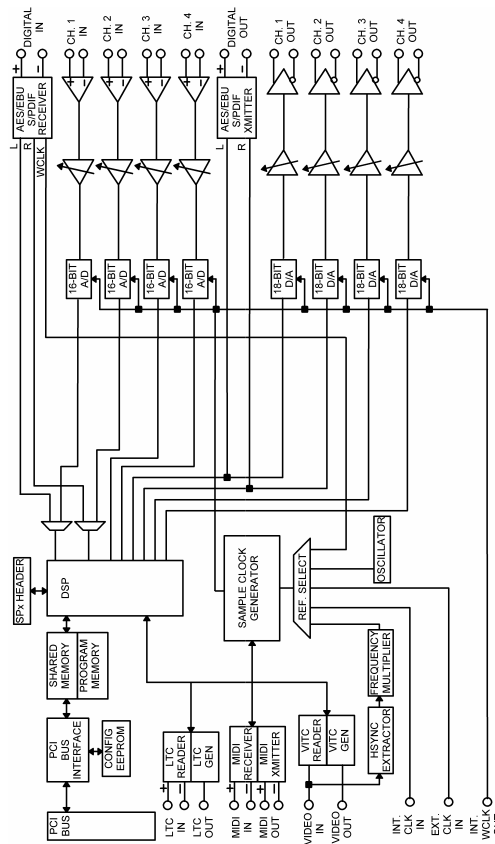

Analog Audio Analog audio enters the *StudioCard* through its four balanced audio inputs. Each channel's differential signal is converted to a single-ended signal by a differential amplifier and then adjusted in a variable gain stage according to the desired nominal level of either -10 dBV or +4 dBu. The signal is then converted to digital by a 20-bit sigma delta analog-to-digital converter.

Data from each audio input channel is received by the DSP and routed to one of eight audio device streams. Each audio device is visible to host applications in the form of a standard multimedia device. Each device has dedicated buffers that are sized to accommodate system latencies.

Analog audio for each of the *StudioCard's* four output channels is derived from a mix of up to eight audio devices. The DSP is responsible for mixing the data from each device stream and routing the mixed signal to each channel's 20-bit sigma delta digital-to-analog converter. The signal is then adjusted in a variable gain stage according to the desired nominal level of either -10 dBV or +4 dBu and then converted from single-ended to differential for balanced line transmission.

Digital Audio Digital audio enters the *StudioCard* through a transformer-coupled digital input, which can be switched to conform to either AES/EBU or S/PDIF electrical standards. The signal then enters a receiver circuit that extracts digital audio data and a word clock. The two channels of digital audio data are sent to a multiplexer that can selectively route digital audio data to the DSP instead of data from audio input channels 1 and 2. The extracted word clock is routed to the sample clock source multiplexer where it can be selected as a reference for the sample clock generator.

Outgoing digital audio data is identical to the data sent to the D/A converters for analog output channels 1 and 2. A digital audio transmitter formats the data, then level and impedance are adjusted for either AES/EBU or S/PDIF and then sent out as transformer-coupled digital audio output.

Sample Clock Generator

The *StudioCard's* sample clock generator generates a word clock, at the desired sample rate, and related clocks for the A/D and D/A converters based on a selected clock reference. The clock reference, which can have a frequency of 24 kHz to 54 MHz, is multiplied by an appropriate factor by a phase-locked loop circuit to create the output clocks.

Clock reference sources include the on-board DSP clock, video horizontal sync, a clock from an adjacent board received on the internal clock input, an external clock received from the external clock input on the digital I/O connector, and a word clock from the digital audio input. The generator supports clocks of word and non-word types received from the external clock input. Word clocks are processed in a manner so that phase synchronization with external devices is maintained.

The word clock output of the generator is available at the internal clock output connector. This signal is typically used as a clock reference input to an adjacent board, but can be routed to the host computer's rear panel for use by external devices.

MIDI The MIDI input and output ports adhere to the MIDI specification for optoisolated connections. Data is received and transmitted by an on-board, buffered UART. Data received by the UART is read by the DSP where it is time stamped, parsed into MIDI messages, and inserted in a buffer for transfer to the host PC. Similarly, outgoing MIDI data is received by the DSP and then sent to the UART.

SMPTE (LTC) The LTC receiver, which receives its signal from the LTC input, meets SMPTE and EBU longitudinal time code specifications. It extracts the data, at a frame rate and format (NTSC or PAL) set by the DSP, from the incoming signal to form a SMPTE frame and then stores it in a receive buffer. The DSP reads this buffer when it is full and stores it in a mailbox register for the host. If desired, the DSP will convert the LTC frame data into MIDI time code (MTC) and merge the resulting message into the MIDI input data stream.

The LTC output is connected to the LTC generator which transmits a standard LTC signal. The DSP controls the generator's frame rate, format, gain, output edge rate (SMPTE or EBU type), and sync source. The DSP also supplies frame data from the host or, when jam sync mode is selected, data is derived from the LTC input, VITC input, or MIDI input.

Video The video input provides a connection for incoming composite video to a horizontal sync extractor circuit and a vertical interval time code (VITC) reader. The horizontal sync extractor extracts a sync pulse from the video signal and then performs a frequency multiplication to create a clock that can be used as a reference for the sample clock generator. The VITC reader, which meets SMPTE VITC specifications, reads VITC frame data and then stores it in a receive buffer. The DSP reads a buffer when it is full and stores it in a mailbox register for the host. If desired, the DSP will convert the VITC frame data into MTC and merge the resulting message into the MIDI input data stream. The DSP controls the frame rate, format (NTSC or PAL), and video scan line of the reader.

The composite video signal available at the video output is derived from a VITC generator that is capable of inserting a burned-in time code window. The DSP controls the generator's frame rate, format, VITC video line, and sync source. The DSP also supplies frame data from the host or, when jam sync mode is selected, data is derived from the LTC, VITC, or MIDI input. The burn-in window can be enabled or disabled and displays time code from either the VITC or LTC generator or from the LTC, VITC, or MIDI input. When the VITC generator and burn-in window are disabled, the video output acts as a video feedthrough of the video input.

DSP The DSP is responsible for handling all of the *StudioCard's* on-board resources and communicating with the host. These tasks include the following:

- ✎ Digital audio buffer management, mixing, and audio device routing
- ✎ A/D and D/A control
- ✎ Digital audio transmitter and receiver control
- ✎ Sample clock generator control
- ✎ SMPTE time code generator and receiver control, and time code message formatting
- ✎ MIDI tasks including buffer management, message parsing, time stamping, system exclusive and real-time message handling, and SMPTE time code to MTC conversion
- ✎ Host interface message processing, data transfers, and interrupts
- ✎ SPx header interface data handling and control

This page intentionally left blank.